

How to Cite:

Farhan, M. A., Mustafa, M. M., Heikal, Y. A., & Atia, M. F. (2022). Maximizing the utilization of solar energy in drying of potato. *International Journal of Health Sciences*, 6(S2), 7493–7503. <https://doi.org/10.53730/ijhs.v6nS2.6781>

Maximizing the utilization of solar energy in drying of potato

Mustafa A. Farhan

Agric. Engineering Dept., Fac. of Agric., Ain Shams Univ., P.O. Box 68, Hadyek Shoubra, 11241, Cairo, Egypt

Corresponding author email: almustafaaljumaily@gmail.com

Mubarak M. Mustafa

Agric. Engineering Dept., Fac. of Agric., Ain Shams Univ., P.O. Box 68, Hadyek Shoubra, 11241, Cairo, Egypt

Yhia A. Heikal

Food Sci. Dept., Fac. of Agric., Ain Shams Univ., P.O. Box 68, Hadyek Shoubra, 11241, Cairo, Egypt

Mohamed F. Atia

Agric. Engineering Dept., Fac. of Agric., Ain Shams Univ., P.O. Box 68, Hadyek Shoubra, 11241, Cairo, Egypt

Abstract---This study was proceeded to adjudge a maximizing the utilization of solar Energy in the drying of potato, Experimental work was proceeded under different levels of temperature and thickness of Potato slices “2-3mm” at constant air velocity of 0.78 m/min. The experimental measurements included moisture content Potato slices, air temperature, air relative humidity, solar drying efficiency and changes of the drying rate Potato Measuring the utilization rate of solar energy, with mirrors or without mirrors. The moisture content of potato decreased from 80.9 to 5.55 kg/kg for potato slices treated using mirrors, this decrease in moisture content was greater than when the slides were not treated and without mirrors.

Keywords---solar energy, drying potato, maximizing utilization.

Introduction

Potato (*Solanum tuberosum* L.) is a source of both food and income in the growing countries of the world which able to change greatly the food security of countries because of its high productivity per unit area and time compared to other crops. It is commonly produced for its tuber (underground modified stem) which mainly

contains carbohydrates. Potato is a multipurpose crop, highly popular worldwide and served in a variety of ways. It is a good source of essential protein, vitamins and minerals. Potato is a moderate source of iron while high in vitamin C content which promotes iron absorption. It is a good source of vitamin B1, B3 and B6 and minerals such as potassium, phosphorus and magnesium. Potatoes also contain dietary antioxidants, which may play a part in preventing diseases related to ageing, and dietary fiber, which benefits health (Tolessa, 2018).

The total world production for potatoes in 2016 was 354,189,041 million tonnes. China was by far the largest producer, accounting for 26.3% of world production. Total production in 2019 was 370,436,581 million tonnes (FAO, 2020). One of the most important potential applications of solar energy is the solar drying of agricultural products. Losses of fruits and vegetables during their drying in developing countries are estimated to be 30–40% of production. The postharvest losses of agricultural products in the rural areas of the developing countries can be reduced drastically by using well-designed solar drying systems. Solar drying is becoming a popular option to replace mechanical thermal dryers owing to the high cost of fossil fuels which is growing in demand but dwindling in supply. This paper presents the viability of solar dryer for agricultural sustainability and food security (J.T Liberty, 2014).

Natural convection solar drying has advantages over forced convection solar drying as it requires lower investment though it is difficult to control the drying temperature and drying rate. Due to low cost and simple operation and maintenance, natural convection solar drier appears to be the obvious option and popular choice for drying of agricultural products. Natural convection solar drier can be classified as (i) indirect natural convection solar drier, (ii) direct natural convection solar drier and (iii) mixed mode natural convection solar drier (Fadhel, 2015).

The current study aims at testing and evaluating a maximizing the utilization of solar energy in drying of potato slices. and measuring the utilization rate of solar energy under different operating conditions, evaluation of drying system performance measuring the drying rates of potatoes under the different conditions for the dryer to operate.

Materials and Methods

Potatoes used for the study were purchased from a local market, checked for bruises, spots and other damages. They were washed and peeled using a peeler. The initial water content was about (70-82 % (w.b)). The potatoes were thoroughly cleaned to remove any dirt or dust particles attached to the surface. peeled and sliced using a special blade to get slices thickness of 2 to 3 mm and After cutting, it is immersed in boiling water for 5 minutes, then cooled in ice water and The sample was dipping in a solution containing 0.02% citric acid solution for a 5 min. Experiments were also conducted on potatoes without pre-treatment.

Experimental Set-Up

The solar drier construction and dimensions: Solar collector, the absorber plate of the collector is a black painted galvanized steel sheet of dimensions (2m in length and 1m in width). It was painted with a mat black paint in order to increase its absorptivity. The collector glass cover is a single glass cover with thickness of 0.6 cm and its frame made from an aluminum sheet. The distance between the glass cover and the absorber plat was of 6 mm along the collector was used as an insulating ,which made the air passage. Glass wool material for all collector sides. The body of the collector was made from galvanized steel sheets; collector air vent was covered by wire mesh. It was investigated with a fixed inclined of 30° from the horizontal and oriented it towards the south direction and Reflective mirrors have been added that move at an angle from (zero to 180) degrees, as they are moved every half hour towards the sun to reflect the heat on the surface of the solar collector and to increase the temperature of the solar collector as depicted in figure (1).

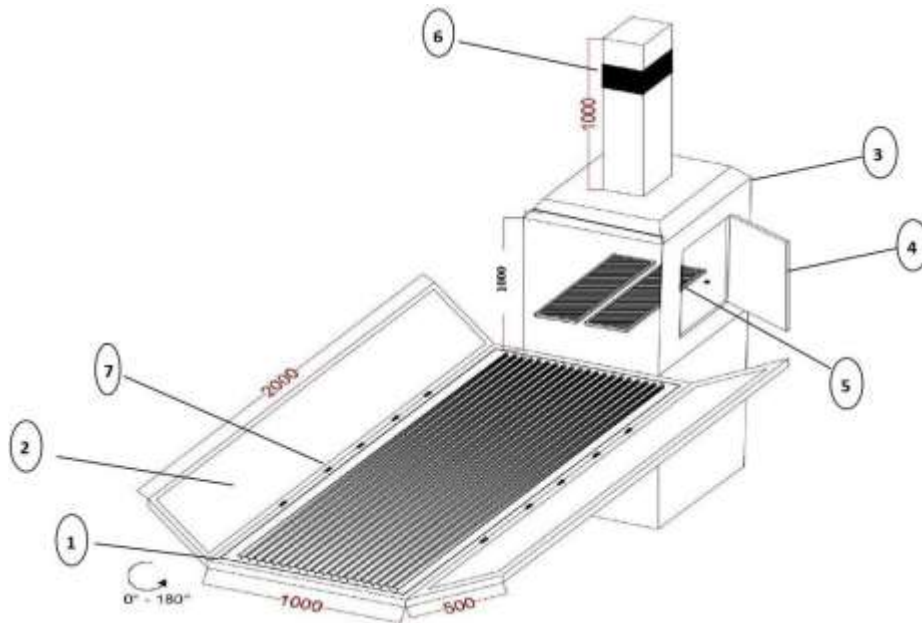

Fig (1) A diagram showing the parts of a solar dryer

- 1- The solar collector
- 2- The mirror
- 3- The drying chamber
- 4- The dryer door
- 5- Drying trays
- 6- Air intake fan
- 7- Detailed door

Experimental treatments

- 1- Treatments of potato slices included (treating with a solution containing 2% citric acid for 5 min and untreated samples)
- 2- Distinct thickness of potato slices (2-3mm) respectively with a constant air velocity of 0.78 m/min.
- 3- Mirrors were used in the experiments, and mirrors were not used in other experiments.

Experimental Measurements and Instrumentation

1. Potato moisture content
The initial and final moisture contents of potato slices were determined using the method described by *Pekke et al, (2013)* using an electric oven at 105°C for 2 hours.
2. Air velocity:
A digital air velocity instrument connected with a velocity probe model (731A) to calculate the exhaust fan air velocity
3. Air temperature and relative humidity:
A temperature and relative humidity sensor module model DHT22 was used for measuring both parameters of the drying air during the experimental work.
4. Solar energy measurement:
The solar radiation meter model TM-206 was used for measuring the solar radiation flux incident during the experimental work

Experimental procedure

Before each run, the dryer is adjusted and all connections to sensors are checked Temperature, humidity, and air velocity and cell weight. That the dryer is running stably, their drying is placed on the drying trays in the drying chamber. And then measure (the weight of the sample temperature, temperature, speed, humidity and humidity every 10 minutes during the drying process throughout the day and night by the Arduino device).

Thermal efficiency of the solar collector

Solar energy available (Q):

$$Q = R. A_c, \text{ Watt (1)}$$

Absorbed solar energy (Q_a):

$$Q_a = \tau. \alpha. R. A_c, \text{ Watt (2)}$$

Absorption efficiency (η_a):

$$\eta = \frac{Q_a}{Q}, \% \quad (3)$$

Useful heat gain to storage (Qc)

$$Q_c = m \cdot a \cdot C_p \cdot (T_{ao} - T_{ai}), \text{ Watt (4)}$$

Heat transfer efficiency (η_h):

$$\eta_h = \frac{Q_c}{Q_a} \times 100, \% \quad (5)$$

Solar collector heat losses (QL):

$$Q_L = Q_a - Q_c, \text{ Watt (6)}$$

Overall thermal efficiency (η_o):

$$\zeta = \frac{Q_c}{Q} , \% (7)$$

Where:

R: Solar energy flux incident on the surface of solar collector, W/m²

Ac: Surface area of the solar collector, m²

τ : Effective transmittance of solar collector cover system, decimal

$$\tau = \tau_{\max} - 0.00437 \exp [0.0936 (\theta - 30)]$$

α = Effective absorptance of the absorber plate of collector, decimal

$$\alpha = \alpha_{\max} - 0.00476 \exp [0.0940 (\theta - 35)]$$

θ = Solar incident angle

ma: Mass flow rate of air, kg/s.

Cp: Specific heat of air, J/kg/ °C

T_{ao}: Outlet temperature of air, °C.

T_{ai}: Inlet temperature of air, °C.

Thermal efficiency of the solar dryer

The ratio of useful heat energy required for evaporating moisture (Q_{ev}) to the available heat (Q_i) is defined as the thermal efficiency of the solar drying system (η_{thd}). It could be calculated according to (Abdelatif, 1989) as follows:

$$\eta_{\text{thd}} = \frac{Q_{ev}}{Q_i} \times 100, \% (8)$$

$$Q_{ev} = m_{ev} L, \text{ kJ (9)}$$

$$Q_i = Q_u + Q_E, \text{ KJ (10)}$$

Where:

m_{ev} = Mass of moisture removed, kg.

L = Latent heat of vaporization of water, kJ/kg.

Q_E = Electric energy of heaters, kJ.

Q_U = Useful heat gain by the solar collector, kJ.

Results and Discussion

Solar radiation flux incident

The hourly average solar radiation available during the experimental work at the period from October 2021 to March 2022 in Cairo, Egypt was measured and recorded. The hourly average available solar radiation was 762.25 W/m^2 . Fig (1) shows the measured solar energy flux incident during the experimental work. In general, the solar radiation gradually increased from sunrise till it reached the maximum value of 1000 W/m^2 at noon, it then decreased gradually until it reached the minimum value of 65 W/m^2 at sunset. As shown in the figures (2), (3), the temperature rises with the increase in the fall of solar radiation on the solar collector. The temperature of the absorbing plate and the glass plate was higher than the temperature using mirrors than not using mirrors.

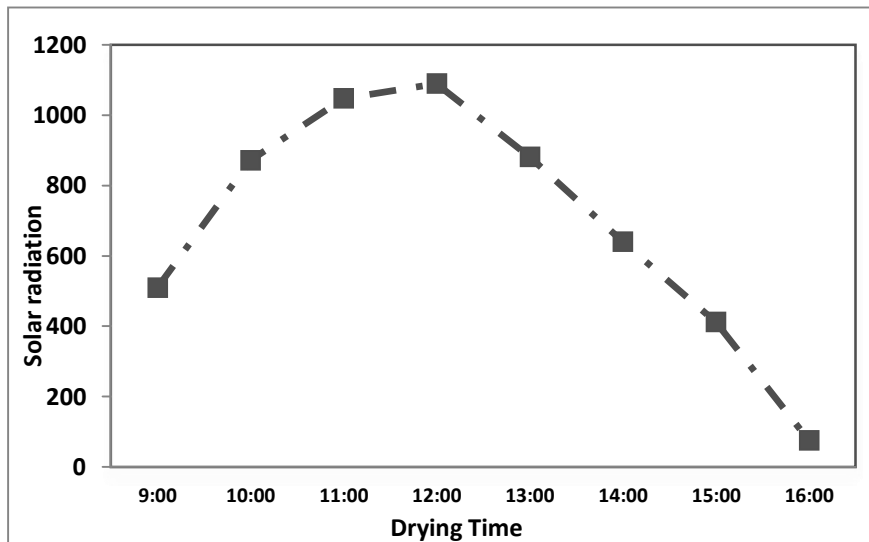
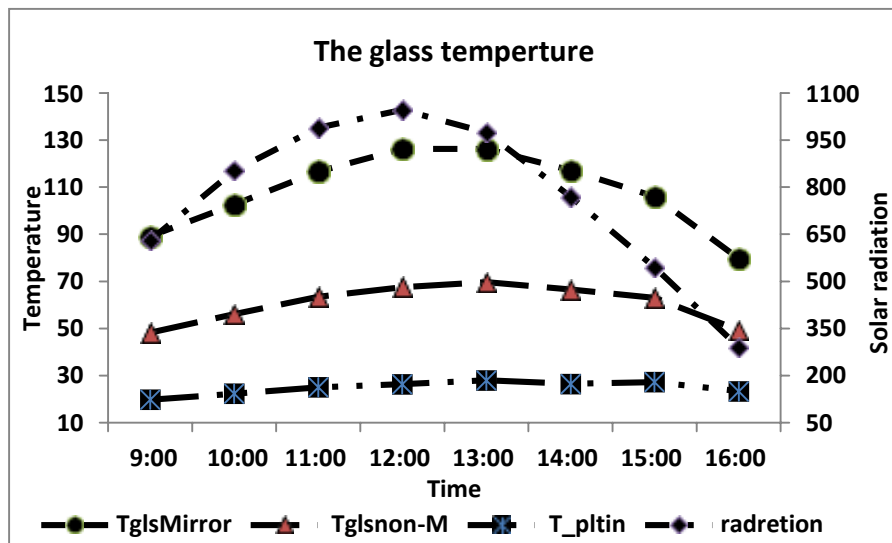
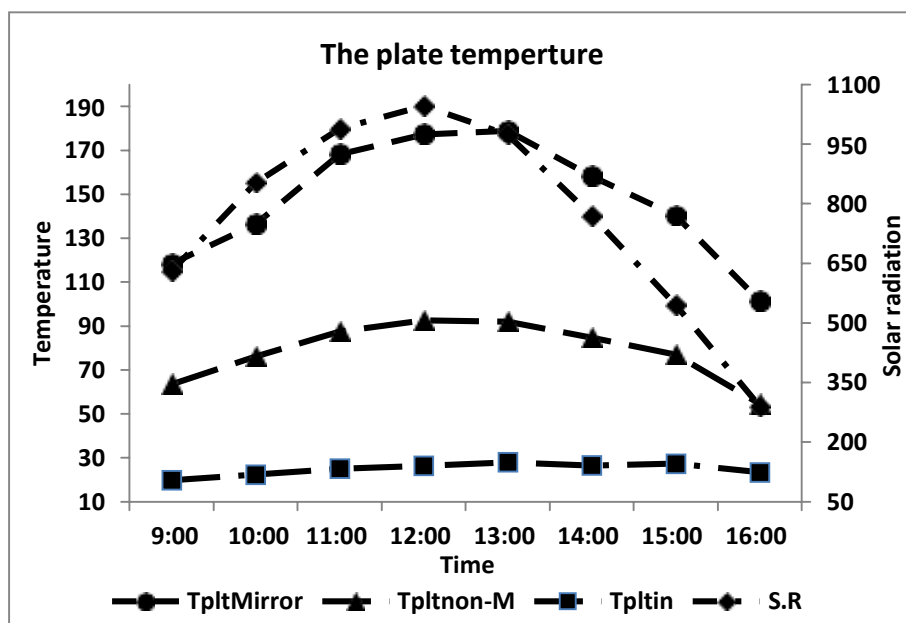

Fig.2. Solar radiation flux incident outside the solar collector as related to day time



Fig(3)The relationship between solar radiation flux incident outside the solar collector and The temperature of the glass plate for the solar collector of with mirror and without mirror as related to day time



Fig(4)The relationship between Solar radiation flux incident outside the solar collector and The temperature of the absorber plate for the solar collector of with mirror and without mirror as related to day time

Air temperature outside and inside the solar dryer

Figs(5) and (6) present the air temperature and relative humidity profile at different positions outside and inside , we notice that temperatures using mirrors are higher than temperatures without using mirrors and we notice that the

relative humidity using mirrors is lower without using mirrors, in the examined solar dryer.

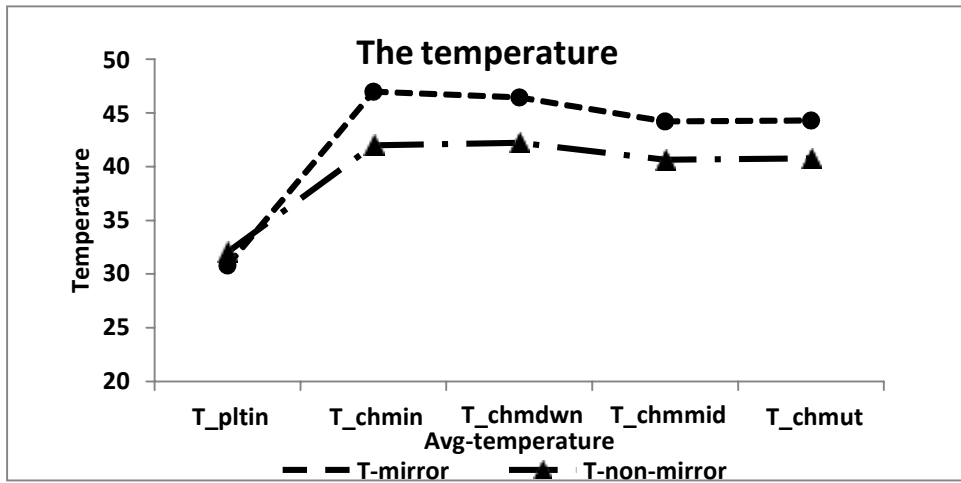

Fig(5) Air temperature at different positions of the dryer used with and without mirrors

Where:

T_pltin: The normal air temperature

T_chmin: The air temperature entering the drying chamber

T_chmdwn: The air temperature on the opposite side of the air inlet of the drying chamber

T_chmmid: The air temperature of the drying room is in the middle

T_chmut: Air chimney temperature for drying room

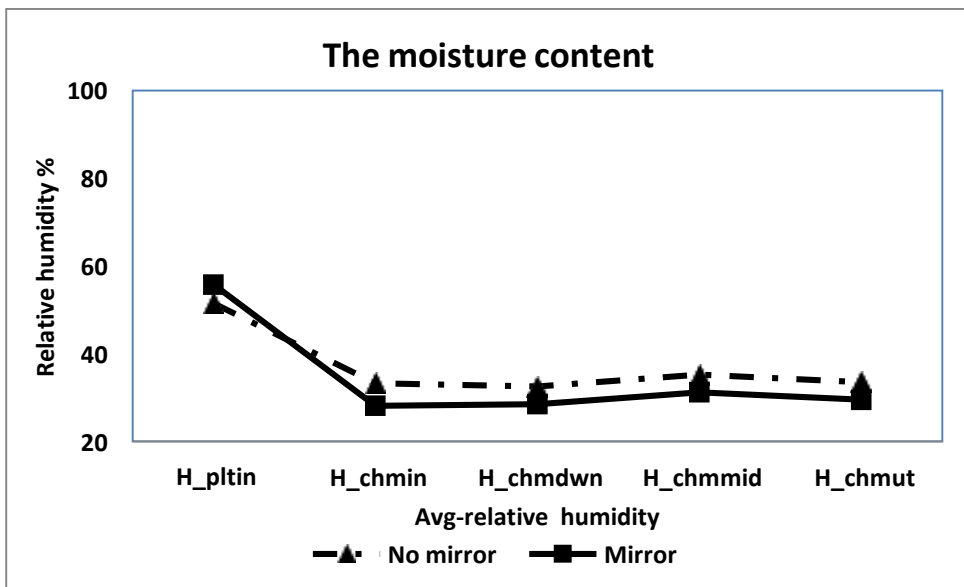

Fig (6) Relative humidity at different positions of the dryer used with and without mirrors

Where:

H_{pltn} : The normal air relative humidity

H_{chmin} : The air relative humidity entering the drying chamber

H_{chmdwn} : The air relative humidity on the opposite side of the air inlet of the drying chamber

H_{chmmid} : The air relative humidity of the drying room is in the middle

H_{chmut} : Air chimney relative humidity for drying room

The moisture content and moisture ratio of potato with mirror and without mirror

As shown in the figures (7) and (8), the difference in the moisture content and moisture ratio using mirrors or without mirrors, we notice that the difference in the moisture content and moisture ratio are increase using the mirrors than without mirrors and The drying time is also reduced.



Fig(7) Variation in moisture content with mirror and without mirror

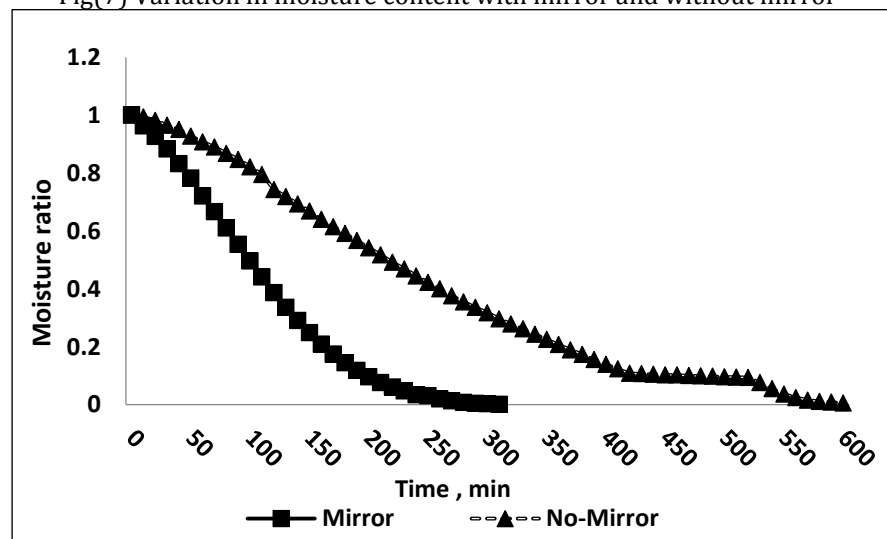

Fig(8) The variation in moisture ratio of with mirror and without mirror

Final moisture content

The moisture content of potato slices treated with mirrors decreased more than the untreated slices and also decreased more than without using mirrors.(Table 1). It can be noticed that the final moisture content of the dried potato slices under the studied conditions almost reached the recommended range of the dried potato 5% r as reported in the literature *S. Chouicha , et al (2013)* . Since the moisture content of dried potato slices was well within the moisture content range of safe moisture level.

Table 1 The initial and final moisture content (% d.b) potato slices treated and untreated with mirrors and without mirrors

With mirror				Without mirror			
Avg.moisture content of potato				Avg.moisture content of potato			
Treated		Untreated		Treated		Untreated	
Initial	Final	Initial	Final	Initial	Final	Initial	Final
80.9091	5.55746	80.9091	9.53159	80.9091	5.60797	80.9091	10.5296

Conclusion

- 1- The temperature of the solar collector using mirrors is higher than not using mirrors
- 2- The air relative humidity using mirrors is lower of without using mirrors.
- 3- The drying rate is increase using the mirrors than without mirrors.
- 4- The moisture content of potato slices treated with mirrors decreased more than the untreated slices and also decreased more than without using mirrors

References

- Abdellatif, S. M. (1989). "Acomparative Study of the Thermal Performance of Solar Panels with Different Diameters of Copper Pipe." *Misr J. Ag. Eng.*, 6(1): 69-77.
- Chouicha, S., Boubekri, A., Mennouche, D., & Berrbeuh, M. H. (2013). Solar drying of sliced potatoes. An experimental investigation. *Energy Procedia*, 36, 1276-1285.
- Fadhel, M I. 2015. *Solar Drying : Fundamentals , Applications*. Hosamani, Ravi, and Satish R Desai. 2013. "Solar Based Temperature Controlled Fruit Drying System" 1: 4-7.
- FAO. 2020. Potatos Market Review: Preliminary Results 2019. Rome www.fao.org/contact-us/licence-request
- Liberty, J. T., Okonkwo, W. I., & Ngabea, S. A. (2014). Solar crop drying-a viable tool for agricultural sustainability and food security. *International journal of modern Engineering Research*, 4(6), 8-19.
- Pekke, M. A., Pan, Z., Atungulu, G. G., Smith, G., & Thompson, J. F. (2013). Drying characteristics and quality of bananas under infrared radiation heating. *International Journal of Agricultural and Biological Engineering*, 6(3), 58-70.
- Tolessa, E. S. (2018). Importance, nutrient content and factors affecting nutrient content of potato. *American Journal of Food, Nutrition and Health*, 3(3), 37-41.